

J. Kennedy

Die for Cutting Screws.

N^o 52,294.

Patented Jan. 30, 1866

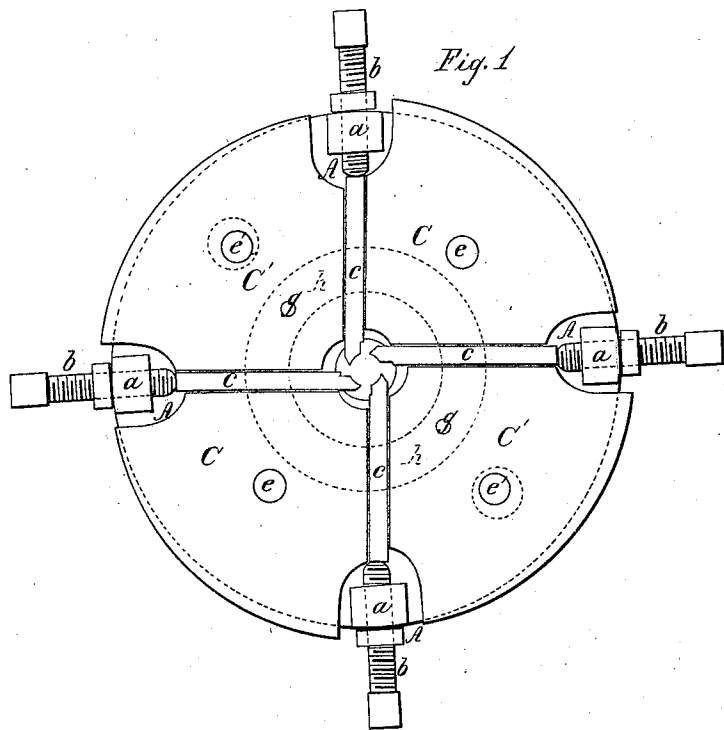

Fig. 1

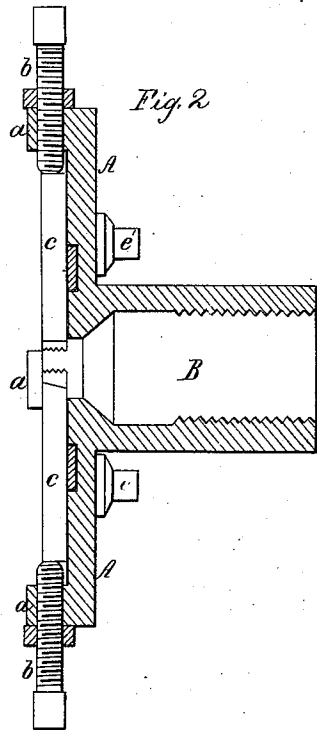

Fig. 2

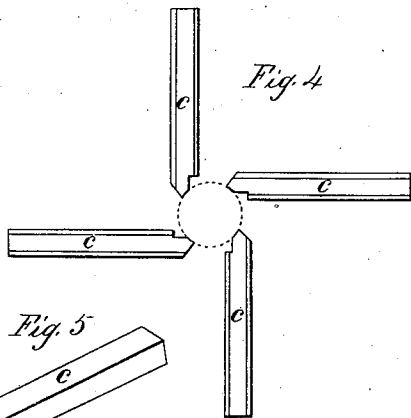

Fig. 4

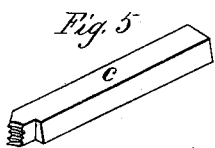

Fig. 5

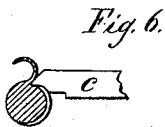

Fig. 6

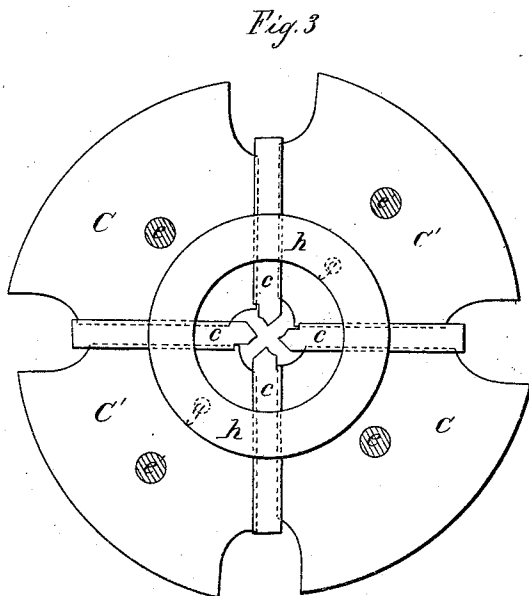

Fig. 3

Witnesses
W. H. ...
Edw. ...

Inventor
J. Kennedy
by his atty
Mason ...

UNITED STATES PATENT OFFICE.

T. KENNEDY, OF MOUNT CARMEL, CONNECTICUT.

IMPROVED SCREW-CUTTING CHUCK.

Specification forming part of Letters Patent No. 52,294, dated January 30, 1866.

To all whom it may concern:

Be it known that I, T. KENNEDY, of Mount Carmel, New Haven county, State of Connecticut, have invented a new and Improved Device for Cutting Screw-Threads; and I do hereby declare that the following is a full, clear, and exact description thereof, reference being had to the accompanying drawings, making a part of this specification, in which—

Figure 1 is a front view of the improved screw-cutter. Fig. 2 is a diametrical section through the same. Fig. 3 is a view of the back side of the dies and segmental adjusting-plates. Fig. 4 shows four dies arranged in positions for recutting. Fig. 5 is a perspective view of one of the cutting-dies. Fig. 6 shows the operation of cutting a thread upon a rod.

Similar letters of reference indicate corresponding parts in the several figures.

The usual mode of cutting screw-threads upon bars or bolts in a turning-lathe is to have the dies applied between fixed guides upon the face of a circular plate in such manner that these dies are arranged in lines pointing to the axis of said plate, and consequently pointing toward the axis of the rod upon which the thread is to be cut. These radial screw-cutting dies scrape the metal rather than cut it, and for this reason the friction is considerable and the cutting-edges of the dies are soon worn out and require recutting.

One object of my invention is to so apply screw-cutting dies to the face of a circular plate that these dies can all be adjusted and set at any desired angle, and also be moved in a direction with their length, thus providing for cutting threads on bars of different diameters, and also preserving the tangential position of the dies with respect to a circle described within the circumference of said bars, as will be hereinafter described.

Another object of my invention is to form the cutting-points of the dies in such manner that they can be readily sharpened when dull upon a common grindstone or oil-stone without the necessity of previously drawing the temper of the metal; also, that these cutting-points can be easily recut with a suitable screw-tap without removing the dies from their face-plate, as will be hereinafter described.

To enable others skilled in the art to understand my invention, I will describe its construction and operation.

In the accompanying drawings a circular plate, A, is represented, having a central hollow sleeve or hub, B, projecting from its back side, as shown in Fig. 1, for receiving the end of a mandrel and supporting the plate A during the operation of cutting threads on rods or bolts. From the flat face of the plate A, and near the circumference thereof, project four lugs, *a a a a*, through which are tapped four adjusting-screws, *b b b b*, the axes of which point toward the center of the plate A, as shown in Fig. 1. These screws are used for the purpose of moving the screw-cutting dies or bits *c c c c* toward the center of the plate A for cutting threads on rods of different diameters. Their ends form abutments for the dies *c*, for preventing them from moving outward while cutting. The jam-nuts on the adjusting-screws *b* (shown in Fig. 1) are used for preventing these screws from jarring loose and losing their set.

The dies *c* are constructed with beveled sides, as shown in Figs. 4 and 5, and they may all be of an equal length. Their cutting ends are first beveled so as to form a **V** or chisel edge, after which one of the beveled sides or ends of each die is serrated by means of a conical screw-tap, as will be hereinafter described. These four dies *c* are secured in place upon the face of the plate A by means of four segmental plates, *C C' C'*, the straight edges of which are beveled correspondingly to the beveled sides of the dies *c*, so that when the segments are brought together with the dies *c* between them, as shown in Figs. 1 and 3, the dies will be held as if they were in dovetail grooves. These segments *C C'* are held in place upon the face of the plate A by means of screws *e e e' e'*, which pass loosely through the plate A and screw into the segments *C C'*. There is but a single holding-screw for each segment, and the holes which are made through the plate A are of sufficient size to admit of all the required adjustments of the segments and dies to adapt the device for cutting threads on rods varying in diameter.

The two segments *C' C'* are pivoted to studs *g g*, which project from a ring, *h*, and which are diametrically opposite each other. This ring *h* is let into a circular recess which is formed in the face of the plate A concentric to its axis, and the ring is allowed to turn loosely in said recess, the pins *g g* always be-

ing equidistant from the center or axis of the plate A.

The two segments C C are not pivoted to the ring *h*, but are allowed to slide upon the face of plate A, so as to accommodate themselves to the adjustments of the pivoted segments C' C', and to serve for holding the bits *c* in place against the edges of the latter segments. The inner angles as well as the outer angles of all the segments are notched, so as to move freely on each side of each lug *a*, and also so as to be out of the way of the rod which passes through the center of the plate A as the operation of cutting a screw-thread upon it progresses.

The object of employing adjustable segments for holding the dies or bits *c* is to enable a person to have the cutting-edges of these dies or bits always tangent to the circumference of the screw-rod, or rod upon which the thread is cut; and the object of pivoting the adjustable segments C' C' to studs *g g*, which are always equidistant from the axis of the plate A, is that all the bits or dies shall be adjusted alike when the segments C C are secured in their places. The adjustments of the segments C C C' C' are made for the purpose of changing the tangent of the dies or bits *c* for cutting threads upon rods of different diameters.

By having the cutting-edges of the dies tangent to the surface of the rod which is to be cut, as shown in Fig. 6, a true cutting action will be obtained and the chips will be thrown up with very little friction, while on the other hand if the cutting-points are directed toward the axis of the rod being cut, a scraping action, attended with considerable friction, will be the result.

When the cutting-edges of the threads on the dies become dull, these dies are adjusted

and set as shown in Fig. 4, and a male screw-tap, which is slightly tapering, is used for sharpening the dies, or rather for recutting the threads thereon; and when the acute angle points of the threads become dull the dies are removed from the face-plate A, and said points sharpened again by applying the beveled ends of the dies to the surface of a grindstone. The points of the threads may be in this manner resharpened until the threads are completely worn off, when the dies may be re-threaded again, as above described.

Having thus described my invention, what I claim as new, and desire to secure by Letters Patent, is—

1. Providing for adjusting the screw-cutting dies upon a face-plate, A, so that they shall always be tangent to the circumference of the body of the screw which is being cut, substantially as described.

2. Sustaining and confining screw-cutting dies *c* upon a face-plate, A, by means of adjustable segments C C C' C', applied to said plate, substantially as described.

3. Pivoting the adjustable segments C' C' to the ring *h* of the face-plate A in such manner that the dies may be all adjusted alike, substantially as described.

4. The combination of the adjusting-screws *b* with means for adjusting the dies *c* and setting them at any desired tangent, substantially as described.

5. Constructing the screw-cutting dies *c* with beveled sides and beveled ends, substantially as described.

T. KENNEDY.

Witnesses:

LEVERETT HITCHCOCK,
HENRY J. BEECHER.